

P2K MODEL

The Safest Design In The Industry



SPECIFICATIONS: STANDARD P2K PUMPING SYSTEMS*

Bore x Stroke	in	1.25, 1.50 x 1.50	1.75 x 1.50	2.00 x 1.50
	(mm)	(32, 38 x 38)	(44.5 x 38)	(50.8 x 38)
Flow Rate	gpm	1.13 – 3.10	2.20 – 4.20	2.87 – 5.53
	lpm	4.27 – 11.73	8.32 – 15.89	10.90 – 20.93
Pump Design Rating	hp	7.5 – 20	10 – 20	15 – 20
	kw	5.6 – 15	7.5 – 15	11.2 – 15
Maximum Discharge Pressure	psi	6,000	4,500	3,500
	bar	414	310	241
NPSPR	psi	2	2	2
	bar	0.14	0.14	0.14
Maximum Suction Pressure	psi	300	300	300
	bar	20.7	20.7	20.7

* Contact ACD for additional P2K pump ratings

FEATURES & BENEFITS

- Vertical pump design eliminates gravitational loading on the piston, extending sealing ring life and providing smoother suction valve operation
- Vertical installation offers less vibration, reduced noise, and a compact system footprint
- V-band clamp secures the sump to the intermediate, allowing quick and easy access to the cold end assembly
- External re-lubrication nipples for roller bearings and crosshead provide extended service life
- Packing rings at top of pushrod are retained in cartridges for easy replacement (no removal of sump and cold end required)
- Motor positioned on the backside of the pumping skid eliminates possible fire, explosion, or hazard in the event of a liquid oxygen leak
- Replaceable crosshead wearband eliminates crosshead piston wear and reduces maintenance costs
- Vertical cold end is submerged inside a vacuum-jacketed liquid sump, minimizing heat leak and increasing system efficiency (particularly in poor suction conditions)
- Pump assembly and spare parts are interchangeable with the PD3000 pump
- Easy cold end maintenance by swiveling the pump and drive end 45°

APPLICATIONS

- Heavy duty cylinder filling
- Medium duty storage filling
- Unattended, automatic storage filling

LIQUIDS PUMPED

- Nitrogen
- Oxygen
- Argon
- Carbon dioxide
- Methane (LNG)
- Ethylene

Para más información comuníquese al
305.888.5353
o al correo electrónico
info@intltec.com



**INTERNATIONAL
TECHNISYSTEMS INC.**

P2K MODEL

OVERALL DIMENSIONS

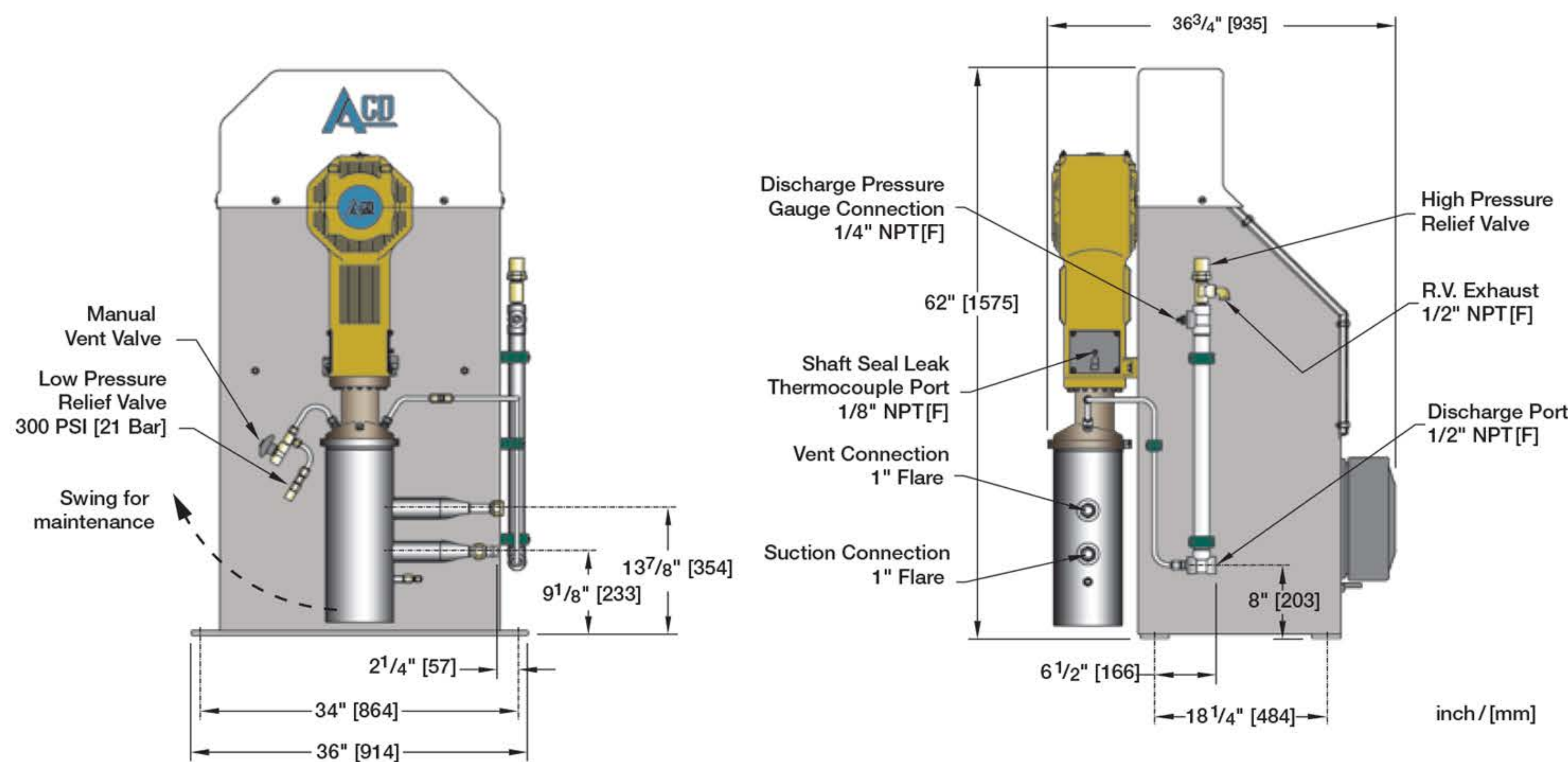

PUMP PERFORMANCE MAP

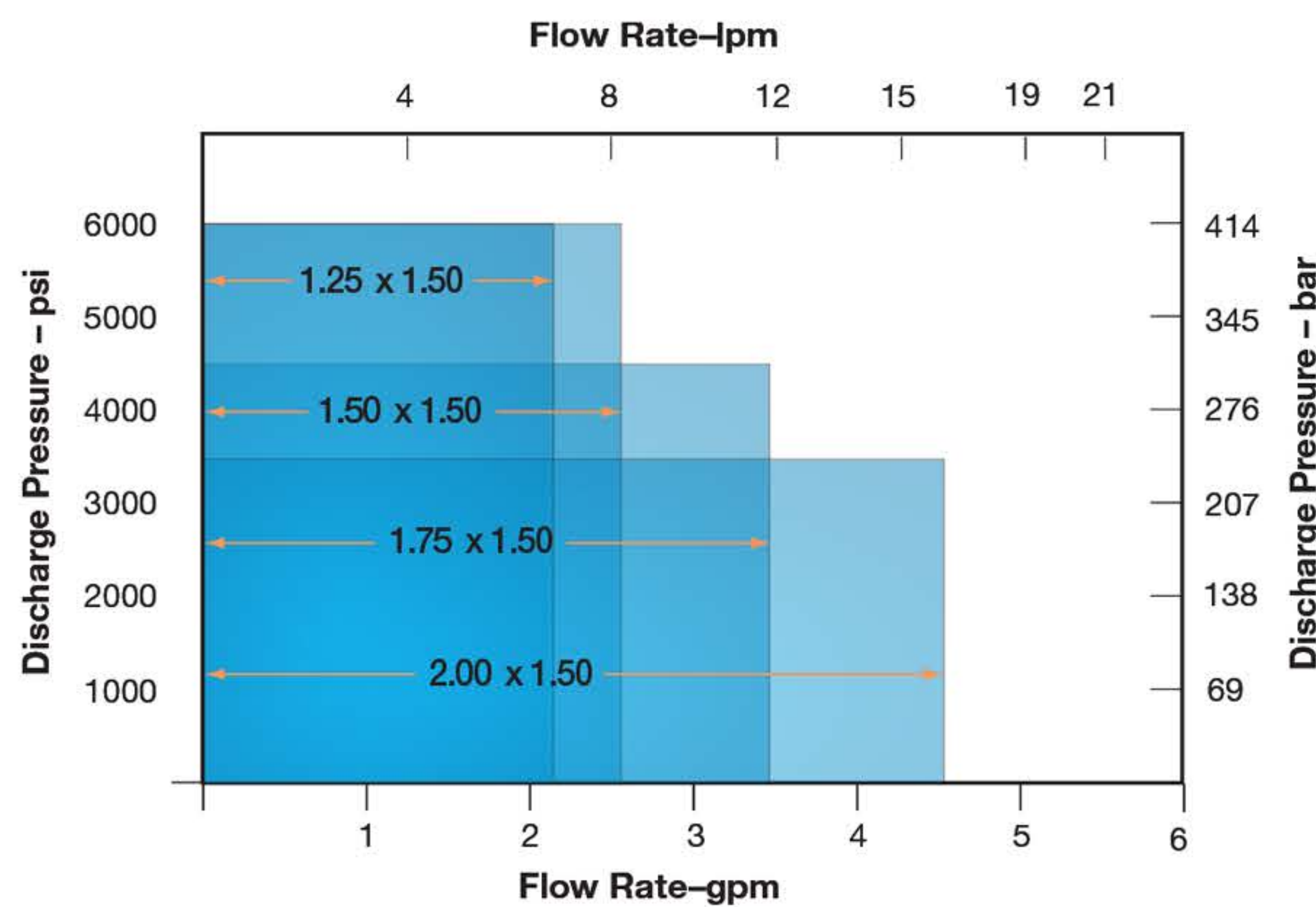

Maximum Capacity Rating:

- 2.55 gpm (9.6 lpm) @ 6,000 psi (414 bar)
- 3.47 gpm (13.1 lpm) @ 4,500 psi (310 bar)
- 4.54 gpm (17.2 lpm) @ 3,500 psi (241 bar)

Lower flows are available by running the pump slower. Contact ACD Engineering for recommendations for flow/pressure specifications not listed.

TYPICAL SCOPE OF SUPPLY

- Grease-lubricated drive assembly and vacuum-jacketed cold end
- Electric motor with belt drive and guard
- Hot-dipped galvanized steel skid frame
- Over pressure switch gauge (shipped loose)
- Control panel with combination motor starter and running time meter (shipped loose), relay logic
- Vent line with manual valve and low pressure relief valve
- Monel suction strainer
- High pressure relief valve with discharge line and surge chamber

OPTIONAL ACCESSORIES

- PLC control panel
- Automatic control panel
- Loss of prime detector
- Discharge check valve
- Cavitation detector
- Shaft seal leak detector
- Flex sections for suction and tank return lines
- Cool down temperature detector
- Auto unloader valve
- Extended cool down lock-up
- Drive purge
- ASME high pressure relief valve
- Monel cold end – for 4,500+ psig oxygen

MANUFACTURING



2321 S. Pullman Street
Santa Ana, CA 92705 USA
1.800.525.4216 (USA only)
+1.949.261.7533
Fax +1.949.261.6285
acd@acdllc.com • acdllc.com



Gutenbergstrasse 1
CH-4142 Muenchenstein Switzerland
+41.61.413.0230
Fax +41.61.413.0233
sales@acdcrysto.com • acdcrysto.com

GLOBAL SERVICE

NORTH AMERICA

Atlanta

Atlanta, Georgia, USA
+1.404.696.8113 • Fax +1.404.696.8116
sales@cryoatlanta.com • cryoindservice.com

California

Santa Ana, California, USA
+1.949.724.8636 • Fax +1.714.641.1921
sales@cryocal.com • cryoindservice.com

Houston

Houston, Texas, USA
+1.281.590.4800 • Fax +1.281.590.4801
sales@cihouston.com • cryoindservice.com

Pittsburgh

Imperial, Pennsylvania, USA
+1.724.695.1910 • Fax +1.724.695.1926
pittcryo@pittcryogenic.com • cryoindservice.com

Red Deer

Red Deer, Alberta, Canada
+1.403.352.4436 • Fax +1.403.352.4439
sales@cryocanada.com • cryoindservice.com

Toronto

Toronto, Ontario, Canada
+1.416.502.1950 • Fax +1.416.502.1952
info@cryocanada.com • cryoindservice.com

INTERNATIONAL

Australia

Dandenong, Victoria, Australia
+61.3.9791.7888 • Fax +61.3.9769.2788
sales.au@cryoquip.com • cryoquip.com

Brasil

São Paulo – SP, Brasil
+55.11.9619.6532 SP
acd@cibrazil.com • cibrazil.com

China

Hangzhou, China
+86.571.8869.0788 • Fax +86.571.8869.0715
hcl@mail.hz.zj.cn • cryoindservice.com

Europe

D-79415 Bad Bellingen Germany
+49.7635.8105.0 • Fax: +49.7635.8965
info@acdcrysto.com • acdcrysto.com

India

Vadodara, Gujarat, India
+91.265.283.0113 • Fax +91.265.283.0112
npatel@acdllc.com • acdcom.com

Korea

Yongin-si, Gyeonggi-do, Korea
+82.31.286.6114 • Fax +82.31.286.6118
info@ci-korea.co.kr • cryoindservice.com

Malaysia

Shah Alam, Selangor D.Ehsan, Malaysia
+603.5740.8770 • Fax +603.5740.8775
cryogen@po.jaring.my • cryoindservice.com

Bulletin No. ACD P2K-R6.10

© 2010 ACD LLC, Printed in USA

SPECIFICATIONS SUBJECT TO CHANGE WITHOUT NOTICE

Para más información comuníquese al
305.888.5353
o al correo electrónico
info@intltec.com



INTERNATIONAL TECHNISYSTEMS INC.